

(19) World Intellectual Property Organization
International Bureau



(43) International Publication Date
11 January 2001 (11.01.2001)

PCT

(10) International Publication Number
WO 01/03058 A1

- (51) International Patent Classification⁷: **G06K 19/07**,
19/077, 7/00
- (21) International Application Number: PCT/US00/17619
- (22) International Filing Date: 27 June 2000 (27.06.2000)
- (25) Filing Language: English
- (26) Publication Language: English
- (30) Priority Data:
09/345,887 1 July 1999 (01.07.1999) US
- (63) Related by continuation (CON) or continuation-in-part (CIP) to earlier application:
US 09/345,887 (CON)
Filed on 1 July 1999 (01.07.1999)
- (71) Applicant (for all designated States except US): **INTERMEC IP CORP.** [US/US]; 21900 Burbank Boulevard, Woodland Hills, CA 91367-7418 (US).
- (72) Inventors; and
- (75) Inventors/Applicants (for US only): **BRADY, Michael,**

John [US/US]; 72 Seven Oaks Lane, Brewster, NY 10509 (US). **BICKMORE, John, Timothy** [US/US]; 769 Windmere Way, Keller, TX 76248 (US). **DUAN, Dah-Weih** [—/US]; 1185 Park Lane, Yorktown Heights, NY 10598 (US). **HEINRICH, Harley, Kent** [US/US]; 463 Gage Road, Brewster, NY 10509 (US). **JOHNSON, Charles, A.** [US/US]; 12401 San Rafael NE, Albuquerque, NM 87122 (US). **KODUKULA, Venkata, S., R.** [IN/US]; 207 Sandpiper Court, Yorktown Heights, NY 10598 (US).

(74) Agents: **BERLINER, Brian, M.**; O'Melveny & Myers LLP, 400 South Hope Street, Los Angeles, CA 90071-2899 et al. (US).

(81) Designated States (national): AE, AL, AM, AT, AU, AZ, BA, BB, BG, BR, BY, CA, CH, CN, CR, CU, CZ, DE, DK, DM, EE, ES, FI, GB, GD, GE, GH, GM, HR, HU, ID, IL, IN, IS, JP, KE, KG, KP, KR, KZ, LC, LK, LR, LS, LT, LU, LV, MA, MD, MG, MK, MN, MW, MX, NO, NZ, PL, PT, RO, RU, SD, SE, SG, SI, SK, SL, TJ, TM, TR, TT, TZ, UA, UG, US, UZ, VN, YU, ZA, ZW.

(84) Designated States (regional): ARIPO patent (GH, GM, KE, LS, MW, MZ, SD, SL, SZ, TZ, UG, ZW), Eurasian patent (AM, AZ, BY, KG, KZ, MD, RU, TJ, TM), European patent (AT, BE, CH, CY, DE, DK, ES, FI, FR, GB, GR, IE,

[Continued on next page]

(54) Title: METHODS OF PLACING RFID TRANSPONDERS IN DENSELY SPACED MEDIA

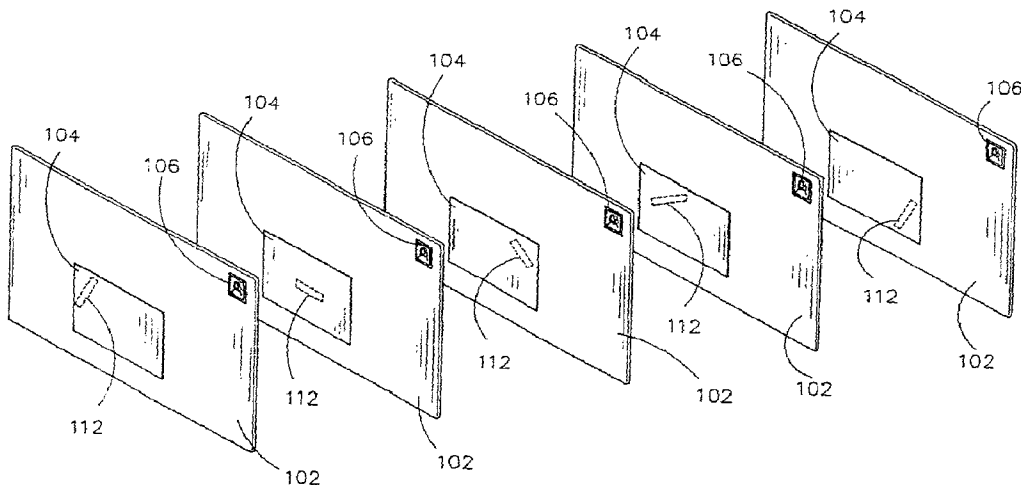

(57) Abstract: Methods and apparatus for associating radio frequency transponders on media such as envelopes, packages, boxes and the like is disclosed. The radio frequency identification transponders are positioned and oriented in labels placed on the media so that the diversity of the radio frequency transponders is increased. This allows the media to be closely spaced or packed together while still permitting the radio frequency transponders associated with each of the media to be powered and interrogated.



WO 01/03058 A1



IT, LU, MC, NL, PT, SE), OAPI patent (BF, BJ, CF, CG, CI, CM, GA, GN, GW, ML, MR, NE, SN, TD, TG).

For two-letter codes and other abbreviations, refer to the "Guidance Notes on Codes and Abbreviations" appearing at the beginning of each regular issue of the PCT Gazette.

Published:

— *With international search report.*

METHODS OF PLACING RFID TRANSPONDERS IN DENSELY SPACED MEDIA

BACKGROUND OF THE INVENTION

1. Field of the Invention

5 The present invention relates generally to radio frequency (RF) transponders such as radio frequency identification (RFID) transponders, and more specifically to improved methods and apparatus for placing RFID transponders on media such as envelopes so that such media may be closely spaced or packed while allowing the RFID transponders to still be read.

10

2. Background of the Invention

Radio frequency transponders may be associated with media such as envelopes, packages, or the like. The radio frequency transponders may then be utilized, for example, to track the movement of the media through a system such as a postal system (e.g., the United States or a foreign country's postal system, a private organization's internal mail system, etc.).

15 In such applications, radio frequency transponders have in the past been placed in identical positions and orientations on each medium. For example, in most postal systems, labels containing routing information (i.e., addresses of the sender and recipient), postage stamps, and the like are placed in predetermined locations on envelopes and packages so that an automated sorting apparatus may be utilized for routing such media to the intended recipient. Radio frequency transponders, likewise, are placed in a specific place on each such medium. However, it has been discovered that

20 when such media are densely spaced or packed, and the radio frequency transponders are placed in the same locations on each medium, a change in the characteristics of the transponder antennas occurs, and the absorption areas of the transponders overlap. This phenomena results in the failure of many of the radio frequency transponders to be powered by the interrogation field produced by the radio frequency identification system and causes the

25 system to be unable to interrogate many of the radio frequency transponders unless the media is first separated. Separation of the media is labor intensive

30

and thereby diminish some of the advantages of using radio frequency transponders to track movement of the media.

Accordingly, it would be advantageous to provide improved methods and apparatus for associating radio frequency transponders with media so that the media may be closely spaced or packed together while still permitting the radio frequency transponders of each of the media to be powered and interrogated.

SUMMARY OF THE INVENTION

10 The present invention is directed to novel methods and apparatus for placing radio frequency transponders on media such as envelopes, packages, boxes, folders, cards, and the like, so that the diversity of the radio frequency transponders is increased. By increasing the diversity of the radio frequency transponders, the present invention provides a significant advantage over
15 conventional ways to associate transponders with such media by allowing the media to be closely spaced or packed together while still permitting the radio frequency transponders of each of the media to be powered and interrogated.

In accordance with a first aspect of the invention, a radio frequency transponder may be positioned and oriented on a medium so that diversity of
20 the transponder is increased. For example, in an exemplary embodiment, a radio frequency identification label suitable for use in identifying and/or tracking the movement of media is disclosed. The radio frequency identification label includes a radio frequency transponder affixed thereto. The radio frequency transponder is positioned and oriented on the label such
25 that when the label is attached to one of the closely spaced media, at least one of position diversity, polarization diversity, and directional diversity of the radio frequency transponder is increased and overlap of the absorption areas of the radio frequency transponder with other transponders is reduced.

In accordance with a second aspect of the invention, a radio frequency
30 identification system suitable for identifying, routing, and/or tracking movement of media is disclosed. The radio frequency identification system includes a radio frequency interrogator which generates a radio frequency

interrogation field suitable for interrogating radio frequency transponders attached to the media, preferably utilizing the diversity methods of the present invention. A chamber such as a metallic or metallized cage or tunnel is electromagnetically coupled to the radio frequency interrogator. The media
5 including the radio frequency transponders are placed within or passed through the chamber. The chamber shapes the electromagnetic field emitted by the interrogator into a more uniform distribution and thereby increases the diversity of the interrogating field. As a result, improved communication between the interrogator and the radio frequency transponders is achieved.

10 It is to be understood that both the foregoing general description and the following detailed description are exemplary and explanatory only and are not restrictive of the invention claimed. The accompanying drawings, which are incorporated in and constitute a part of the specification, illustrate an embodiment of the invention and together with the general description, serve
15 to explain the principles of the invention.

BRIEF DESCRIPTION OF THE DRAWINGS

The numerous objects and advantages of the present invention may be better understood by those skilled in the art by reference to the accompanying
20 figures in which:

FIG. 1A is an isometric view of closely spaced media having labels including RFID transponders;

FIG. 1B is an isometric view of a tray of closely spaced media such as shown in FIG. 1A;

25 FIG. 1C is an isometric view of a bundle of closely spaced media such as shown in FIG. 1A;

FIG. 2 is an isometric view illustrating problems in the placement of RFID transponders on labels affixed to the media shown in FIGS. 1A, 1B, and
1C;

30 FIG. 3 is an isometric view illustrating diversity methods of placing RFID transponders on densely spaced media such as shown in FIGS. 1A, 1B, and 1C;

FIG. 4 is an exploded isometric view illustrating labels having integral RFID transponders placed therein in accordance with the present invention;

FIG. 5 is a diagrammatic illustration of exemplary apparatus for fabricating labels such as shown in FIG. 4;

5 FIG. 6 is an isometric view illustrating diversity methods of placing RFID transponders on the media;

FIG. 7 is an isometric view illustrating position diversity in placing RFID transponders in the label;

10 FIG. 8 is an isometric view illustrating polarization diversity in placing RFID transponders in the label;

FIG. 9 is an isometric view illustrating directional diversity in placing RFID transponders in the label; and

15 FIGS. 10A-10C are diagrammatic views illustrating an exemplary radio frequency identification system for use with media having radio frequency identification labels in accordance with the present invention.

DETAILED DESCRIPTION OF THE PREFERRED EMBODIMENT

The present invention satisfies the need for methods and apparatus for associating radio frequency transponders with media so that the media may
20 be closely spaced or packed together while still permitting the radio frequency transponders of each of the media to be powered and interrogated. Reference will now be made in detail to the presently preferred embodiments of the invention, examples of which are illustrated in the accompanying drawings. It should be appreciated that like element numerals are used to
25 describe like elements illustrated in one or more of the drawings.

Referring first to FIGS. 1A-1C, densely spaced or packed media 100 are shown. In the exemplary embodiment described herein, media 100 are illustrated as thin packages 102 such as envelopes typically utilized in postal or mail systems (e.g., the United States or a foreign country's postal system, a
30 private organization's internal mail system, etc.). It should be appreciated that exemplary media 100 which may utilize the present invention may also include boxes, folders, magnetic or optical media (floppy disks, optical discs,

etc.), cards, postcards, sheets of paper, or the like. The present invention further anticipates use in a wide variety of applications including filing systems, inventory tracking systems, and wholesale or retail sales applications.

5 Each package 102 includes one or more labels 104 and 106. The labels 104 and 106 preferably have an outer surface suitable for receiving textual (i.e., printed, typed or handwritten) or optically readable (e.g., bar codes, etc.) indicia, and an inner surface which may be coated with an adhesive allowing the label 104 and 106 to be attached to the package 102.

10 For example, when the package 102 is utilized in delivery of mail by a governmental postal system (e.g., the United States Post Office), the package 102 may include a mailing label 104 which may include the address of the recipient and/or the address of the sender. Typically, such packages 102, when mailed, also include a postage label or stamp 106. Certain

15 governmental postal regulations may additionally require that all labels 104, 106 be of approximately the same size, and that the labels 104, 106 be placed at approximately the same location on each of the packages. For example, as shown in FIG. 1A, the mailing labels 104 are placed near the center of package 102, while postage labels or stamps 106 are placed near

20 the upper right hand corner of the package. As will be further described below, diversity performance is actually degraded by placing the labels 104, 106 in the same location, and better diversity performance is achieved by randomly placing the labels on the package 102.

 During processing in a postal system, it is often desirable to closely

25 space or pack the media 100, such as packages 102, together to provide ease of handling and storage. For example, the packages 102 may be densely packed in a holding device 108 such as a tray, drawer, or box as shown in FIG. 1B, or simply stacked and bundled in a bundle 110 as shown in FIG. 1C.

30 Turning now to FIG. 2, radio frequency transponders 112 are shown adhered to packages 102 by mailing labels 104. However, it should be appreciated that the radio frequency transponders 112 may alternately be

adhered to packages 102 utilizing other labels commonly affixed to such packages 102 such as postage labels 106, or dedicated labels used solely for attaching the radio frequency transponders (not shown). Further, the radio frequency transponders 112 may be separately attached to the packages 102 (i.e., not placed in or under a label 104, 106). When media such as packages 102 are densely spaced or packed as shown in FIGS. 1A-1C, the diversity performance of the radio frequency transponders 112 is poor since the absorption areas of the transponders 112 overlap. This may result in the failure of many of the radio frequency transponders 112 to be powered by an interrogation field produced by a radio frequency identification system (described below with respect to FIGS. 10A-10C) and causes the system to be unable to interrogate many of the radio frequency transponders 112 unless the packages 102 are first separated.

To increase diversity performance, in accordance with the present invention, labels utilized for affixing radio frequency transponders 112 to packages 102 (or, alternatively, separately attached radio frequency transponders) are preferably placed in a position on the package 102 having the least degree of symmetry so that when the packages 102 are flipped or rotated the labels and thus the radio frequency transponders 112 are not always laid on top of each other. For example, as shown in FIG. 2, mailing labels 104 containing radio frequency transponders 112 may be placed in an off-center position on the packages 102. This positioning avoids areas of high symmetry, such as the centers of the packages 102 or the center of the edges of the packages 102. Thus, when the packages are flipped or rotated, fewer of the radio frequency transponder's absorption areas 164, 166, 168 (i.e., the generally ellipsoid area surrounding the transponder 112 from which radio frequency energy is absorbed to induce a current in the transponder's antenna) will overlap. The result is a greater probability that the interrogation field will power and interrogate the transponder 112 than would be possible if the label and radio frequency transponder were placed in a position of high symmetry.

Referring now to FIG. 3, an in-label scheme may be utilized to further improve diversity performance of the radio frequency transponders 112. Radio frequency transponders 112 are affixed to labels such as mailing labels 104, or alternatively, postage labels 106 or the like which are then adhered to media such as packages 102. The radio frequency transponders 112 are positioned and oriented on the labels 104 so that each of the transponders 112 has a generally unique and distinct combination of position and orientation when the labels 104 are affixed to each package 102 being processed. When the packages 102 are closely spaced together (e.g., grouped in a tray 108 or bundled in a bundle 110 as shown in FIGS. 1B and 1C) this unique and distinct position and orientation reduces the amount of overlap of the absorption areas of the radio frequency transponders 112 since at least one of position diversity, polarization diversity, and directional diversity of the radio frequency transponders 112 is increased.

As shown in FIG. 3, each label 104 includes a first or outer surface suitable for receiving at least one of textual and optically readable indicia such as handwritten textual material, printed or typewritten textual material, bar codes, etc. Such indicia may be preprinted on the label 104 prior to its application to the package, or, alternately, may be printed to the label after its application to the package. A second or inner surface is utilized to attach the label 104 to a package 102. The second surface is preferably at least partially coated with an adhesive for adhering the label 104 to the package 102. A "core" radio frequency transponder 112 is affixed to each label 104 so that the radio frequency transponder 112 has a generally unique and distinct combination of position and orientation. For example, in an exemplary embodiment, the radio frequency transponder 112 may be adhered to the label 104 in a substantially random fashion (see FIG. 5, described below). Thus, there would be a high probability that the radio frequency transponders 112 of any two labels 104 would have different positions and/or orientations.

The radio frequency transponder 112 is comprised of a dielectric substrate having an area less than the area of the surface of the label 104. Exemplary substrate materials include materials such as FR-4 (fire resistance

4) epoxy resin, polyimide, polyester and the like. In FIG. 4, the substrate 212 is shown as being rectangular in shape; however, it should be appreciated that the substrate may alternatively have other geometric or even irregular shapes (i.e., circular, oval, square, triangular, curvilinear, etc.) without departing from the scope and spirit of the invention. An antenna circuit is formed as an integral part of the substrate. A low power radio frequency circuit such as a radio frequency identification integrated circuit (RFID IC) is mounted to the substrate. The radio frequency circuit is coupled to the antenna circuit which enables the transponder 112 to sense the interrogating field (and/or, where appropriate, a programming field). The antenna circuit is also used by the transponder 112 to transmit a response to an interrogation. Preferably, the radio frequency circuit is mounted to the substrate and coupled to the antenna circuit via known methods such as wire bonding, chip-on-board (COB), chip-in-board (CIB), or the like. The radio frequency circuit and antenna leads may be coated with an encapsulant, such as a "glob-top" epoxy, or the like, and/or laminated so that they are protected from damage due to environmental contaminants or handling.

Insulation of the radio frequency transponder's antenna may also be utilized to further improve diversity performance. The insulation provides a static space about the transponder 112 which reduces the effect of dielectric loading on the transponder's antenna by the surrounding environment (i.e., other radio frequency transponders). The thickness of the static space may be small compared to the wavelength (λ) of the antenna (e.g., approximately 3 to 5% of the wavelength (λ) for a dipole antenna) while still reducing the effect of the surrounding environment.

More particularly, in a preferred exemplary embodiment, a label 104 is comprised of an indicia receiving layer 130 and an insulating layer 136 adhered to the indicia receiving layer 130. The indicia receiving layer 130 includes an outer layer 132 which provides the first or outer surface and a second insulating layer 134 affixed to the outer layer 132 opposite the first or outer surface. Preferably, the radio frequency transponder 112 is laminated or sandwiched between the insulating layer 136 and the second insulating

layer 134 of the indicia receiving layer 130. The radio frequency transponder 112 may further be affixed to label 104 so that the radio frequency transponder 112 has a generally unique and distinct combination of position and orientation as discussed above with respect to FIG. 3. Similarly, as
5 discussed in the description of FIG. 2, the label 104 is preferably placed in an area of low symmetry 138. The outer layer 132 is preferably made of a material such as paper which is suitable for receiving printed or hand-written indicia. The first and second insulating layers 134, 136 preferably comprise a thin dielectric material such as expanded polystyrene. It should be
10 appreciated that substitution of other insulating materials by one of ordinary skill in the art would not depart from the scope and spirit of the invention.

Referring now to FIG. 5, an exemplary process for fabricating radio frequency transponder equipped labels 104 is shown. The insulating layer 134 is adhered to the outer layer 132 to form the indicia receiving layer 130.
15 Alternatively, the indicia receiving layer 130 may be formed as a single piece having an outer surface suitable for receiving textual or optically readable indicia. The radio frequency transponder 112 is placed on the insulating layer 130. The insulating layer 136 is then adhered to the first insulating layer 134 so that the radio frequency transponder 112 is laminated or sandwiched
20 between the insulating layer 134 of the indicia receiving layer 130 and the insulating layer 136. An adhesive is applied to the exposed surface of the insulating layer 136 for adhering the label 104 to a media such as packages 102 (shown in FIGS. 1A-1C). The radio frequency transponder 112 may be positioned and oriented on the insulating layer 134 in a substantially random
25 fashion so that there would be a high probability that the radio frequency transponders 112 of any two labels 104 would have different positions and/or orientations. Random positioning of the radio frequency transponders can most easily be achieved via a simple pick-and-drop mechanism.

In FIG. 5, an exemplary pick-and-drop apparatus is shown for randomly
30 positioning and orienting radio frequency transponders 112 on labels 104. The indicia receiving layer 130 is positioned on a carriage assembly 142 so that the insulating layer 134 is facing upward. The carriage assembly 142

positions the indicia receiving layer 130 within a chamber or cylinder 146 having a cross-sectional area that is the same or smaller than the area of insulating layer 134. A feeder assembly 144 drops a radio frequency transponder 112 from the top of the chamber 146. The transponder 112 falls
5 through chamber 146 and lands on the insulating layer 134. By dropping the radio frequency transponder 134 onto the insulating layer 134, the position and orientation of the radio frequency transponder 112 on the insulating layer 134 is made chaotic or random. To further increase the randomness of the transponder's position and orientation on the insulating layer 134, the feeder
10 assembly 144 may drop the transponder from a randomly selected point at the top of the chamber 146. Alternatively, tumblers (not shown) may be included within the chamber 146 that would introduce random movement of the transponder as it falls through the chamber. Carriage assembly 142 may then move the indicia receiving layer 130 out of the chamber 146 where
15 insulating layer 136 is adhered to insulating layer 134 so that the radio frequency transponder 112 is laminated or sandwiched therebetween. Preferably, the random position and orientation of the radio frequency transponder 112 is not disturbed by the addition of the insulating layer 136. The outer surface of the insulating layer 136 may be coated with an adhesive
20 substance (e.g., glue) so that it may be affixed to a medium such as the package 102 (as shown in FIG. 4). Alternatively, a final adhesive layer (e.g., a two sided adhesive tape, etc., not shown) may be affixed to the insulating layer 136.

The carriage assembly 142 is comprised of a conveyor belt or roller
25 system which moves the label 104 in its various stages of completion through the fabrication process. It should be appreciated, however, that many kinds of different carriage assemblies are also possible. For example, an alternative carriage assembly could comprise a stationary support positioned beneath the chamber 146. The indicia receiving layer 130 could be positioned on such a
30 carriage assembly by a robotic mechanism or by hand.

Further, it should be appreciated that an important function of the chamber 146 is utilized to ensure that the radio frequency transponders 112

fall onto the indicia receiving layer 130. Nevertheless, the chamber 146 may be eliminated by moving the feeder assembly 144 closer to the carriage assembly 142. The feeder assembly 144 may then place the radio frequency transponder 112 directly onto the indicia receiving layer 130. Finally, it should be appreciated that while true random placement of radio frequency transponders 112 on the label 104 is preferred, such random placement may be effectively approximated by placing each radio frequency transponder 112 on the insulating layer 134 in one of predetermined positions and orientations. It should also be appreciated that either or both of the first and second insulating layers 134, 136 may be eliminated if desired without departing from the scope and spirit of the invention. For example, if insulation of the radio frequency transponder 112 is unnecessary or not desired, both insulation layers 134, 136 may be eliminated and the radio frequency transponder adhered to the bottom surface of label 104 which is comprised of only the outer layer 132.

FIGS. 6, 7, 8 and 9, illustrate how diversity performance is improved by the substantially random placement of the radio frequency transponders 112 on the labels 104. As described above, packages 102 are densely spaced or packed together as portrayed in FIGS. 1 A, 1B, and 1C are shown. For clarity of illustration, in FIGS. 6-9, the spacing between adjacent packages 102 has been greatly exaggerated so that the labels 104 affixed to each package 102 can be more easily viewed. The labels 104 are shown placed in approximately the same position and orientation on each package 102. As discussed above, such placement is either required or considered desirable in most systems (e.g., such as governmental postal systems). As shown in FIG. 6, the radio frequency transponders 112 are positioned and oriented so that at least one or preferably all of position diversity, polarization diversity, and directional diversity are increased since overlap of the transponder's absorption areas is reduced. Position diversity, polarization diversity, and directional diversity are illustrated individually in FIGS. 7, 8 and 9, respectively.

As known in the art, each radio frequency transponder 112 absorbs energy from the radio frequency interrogation field within an absorption area surrounding the transponder 112. For example, as shown in FIG. 7, the absorption areas 150 are generally ellipsoid in shape for radio frequency transponders 112 having dipole antennas. When the absorption areas 150 overlap, each radio frequency transponder 112 competes to absorb the available field energy. When this happens, one or both transponders 112 may fail to absorb enough energy to be powered. Typically, the transponder 112 having better impedance matching (e.g., due to manufacturing variations) or being closest to the interrogator antenna will absorb most or all of the available energy. Thus, if multiple packages 102 (i.e., two or more, see FIGS. 1A-1C) are closely spaced together so that all share roughly the same absorption area 150, it is likely that none will absorb enough energy to be powered. Position diversity, as used herein, refers to the reduction in overlap between absorption areas 150 of the radio frequency transponders 112 when the packages 102 are closely spaced together. Less overlap in the absorption areas 150 results in a greater probability that all of the radio frequency transponders 112 can be powered.

Turning now to FIG. 8, the polarization of an electromagnetic wave is defined as the locus or path described by the electric field vector of the wave with respect to time. Normally, the antenna of a given radio frequency transponder 112 will only absorb electromagnetic waves having a particular polarization, such as linear polarization or circular polarization (as indicated by arrows 152 and 154). Polarization diversity, as used herein, exists when two or more radio frequency transponders 112, which may share a similar position on respective labels 104 so that their absorption areas 150 overlap, have distinct orientations (e.g., in FIG. 8, radio frequency transponders are oriented at right angles to each other). The transponders 112 will then absorb waves having different polarizations and will extract energy from different parts of an interrogation field.

In FIG. 9, it can be seen that the dipole antenna of each radio frequency transponder 112 has a characteristic radiation pattern 156, 158.

Radiation of such a dipole antenna is strongest within the patterns 156, 158 and is weakest outside of the patterns 156, 158. Thus, even though the interrogation field is present from all directions, the radio frequency transponders 112 will only absorb energy from electromagnetic waves
5 received along axes within the radiation patterns 156, 158 and will absorb little or no energy from outside of the patterns 156, 158. Directional diversity exists when two or more radio frequency transponders 112, which may share a similar position on respective labels 104 so that their absorption areas 150 overlap, have distinct orientations (e.g., in FIG. 7, radio frequency
10 transponders are oriented at right angles to each other). The transponders 112 will then absorb energy from electromagnetic waves received along different axes (only the axes within their radiation patterns 156, 158).

Referring now to FIGS. 10A-10C, an exemplary radio frequency identification system 200 suitable for identifying, routing, and/or tracking
15 movement of media 100 is shown. The radio frequency identification system 200 includes a radio frequency interrogator 204 which generates a radio frequency interrogation field suitable for interrogating radio frequency transponders attached to the media 100. A chamber 206 is electromagnetically coupled to the radio frequency interrogator 204. The
20 chamber 206 shapes the electromagnetic field emitted by the interrogator 204 into a more uniform distribution and thereby increases the diversity of the interrogating field. As a result, improved communication between the interrogator and the radio frequency transponders on media 100 placed within or passed through the chamber. In a preferred embodiment, the chamber 206
25 is comprised of a metal or metallized cage or tunnel extending over a carriage assembly 202 for feeding the media 100 into the chamber 206 where radio frequency transponders attached thereto may be interrogated. In an exemplary embodiment, the carriage assembly 202 may be comprised of a conveyor belt or roller assembly. Media 100 placed on the carriage assembly
30 202 may be densely spaced or packed as shown in FIGS. 1A-1C. For example, media 100 may be bundled as shown in FIG. 10A, continuously fed as shown in FIG. 10B, or placed in a holder as shown in FIG. 10C. An

example of an enclosure such as chamber 206 used to shape an interrogating electromagnetic field is provided in co-pending U.S. application Serial Number 09/122,300, filed July 24, 1998, entitled "Communicating With Radio Frequency Tags Within Shaped Electromagnetic Fields," which is
5 incorporated by reference herein.

It should be appreciated that any of the methods and apparatus of the present invention maybe utilized either alone or in combination to increase diversity performance. Thus, for example, the radio frequency identification system 200 shown in FIGS. 10A, 10B, and 10C may be utilized in
10 combination with labels 104 having randomly positioned and oriented radio frequency transponders 112 as shown in FIGS. 3, 6, 7, 8, and 9. Such labels 104 may further include one or more insulating layers 134, 136 as shown in FIGS. 4 and 5.

It is believed that the methods and apparatus the present invention and
15 many of its attendant advantages will be understood by the foregoing description, and it will be apparent that various changes may be made in the form, construction and arrangement of the components thereof without departing from the scope and spirit of the invention or without sacrificing all of its material advantages. The form herein before described being merely an
20 explanatory embodiment thereof, it is the intention of the following claims to encompass and include such changes.

Claims

What is claimed is:

1. A radio frequency identification label, comprising:
 - a label having a first surface suitable for receiving at least one of
5 textual and optically readable indicia and a second surface suitable for being
attached to a medium; and
 - a radio frequency transponder affixed to said label, said radio
frequency transponder including an antenna defining an absorption area;
wherein said radio frequency transponder is positioned and oriented
10 such that wherein said label is attached to a first medium in closely spaced
relation to a second medium having a second radio frequency identification
label attached thereto, overlap of the absorption areas of the first and second
radio frequency transponders is reduced.
- 15 2. The radio frequency identification label in accordance with Claim
1, wherein said second surface is at least partially coated with an adhesive
adapted to permit said label to be adhered to the first medium.
- 20 3. The radio frequency identification label in accordance with Claim
1, wherein the radio frequency transponder further comprises:
 - a substrate having an area less than the area of the surface of the
label, said antenna being an integral part of said substrate; and
 - a radio frequency identification circuit attached to said substrate and
bonded to said antenna.
- 25 4. The radio frequency identification label in accordance with Claim
1, wherein the label further comprises
 - an indicia receiving layer; and
 - a first insulating layer adhered to said indicia receiving layer so that
30 said radio frequency transponder is laminated therebetween.

5. The radio frequency identification label in accordance with Claim 4, wherein said indicia receiving layer further comprises:
an outer layer providing said first surface; and
a second insulating layer affixed to said outer layer opposite said first surface so that said radio frequency transponder is laminated between said insulating layer and said second insulating layer.
6. The radio frequency identification label in accordance with Claim 5, wherein at least one of said first and second insulating layers comprise expanded polystyrene.
7. The radio frequency identification label in accordance with Claim 5, wherein said outer layer comprises paper.
8. The radio frequency identification label in accordance with Claim 1, wherein at least one of the first and second media comprise envelopes.
9. The radio frequency identification label in accordance with Claim 1, wherein said radio frequency transponder of said first medium is positioned and oriented with respect said second radio frequency identification label of said second medium to provide at least one of positional diversity, polarization diversity and directional diversity.
10. A radio frequency identification label, comprising:
a label having a first surface suitable for receiving at least one of textual and optically readable indicia and a second surface suitable for being attached to a medium; and
a radio frequency transponder affixed to said label;
wherein said radio frequency transponder is positioned and oriented such that wherein said label is attached to a first medium in closely spaced relation to a second medium having a second radio frequency identification label attached thereto, at least one of positional diversity, polarization diversity

and directional diversity of said first and second radio frequency transponders is increased.

11. The radio frequency identification label in accordance with Claim
5 10, wherein said second surface is at least partially coated with an adhesive for adhering said label to the first medium.

12. The radio frequency identification label in accordance with Claim
10, wherein the radio frequency transponder further comprises:
10 a substrate having an area less than the area of the surface of the label;
an antenna circuit formed as an integral part of said substrate; and
a radio frequency identification circuit attached to said substrate and bonded to said antenna circuit.

15
13. The radio frequency identification label in accordance with Claim
10, wherein the label further comprises
an indicia receiving layer; and
an insulating layer adhered to said indicia receiving layer so that said
20 radio frequency transponder is laminated there between.

14. The radio frequency identification label in accordance with Claim
13, indicia wherein said indicia receiving layer further comprises:
an outer layer providing said first surface; and
25 a second insulating layer affixed to said outer layer opposite said first surface so that said radio frequency transponder is laminated between said first insulating layer and said second insulating layer.

15. The radio frequency identification label in accordance with Claim
30 14, wherein at least one of said first and second insulating layers comprise expanded polystyrene.

16. The radio frequency identification label in accordance with Claim 14, wherein said outer layer comprises paper.

17. The radio frequency identification label in accordance with Claim 5 10, wherein at least one of the first and second media comprise envelopes.

18. A radio frequency identification system suitable for identifying closely spaced media, comprising:

10 a radio frequency interrogator for generating a radio frequency interrogation field suitable for interrogating a radio frequency transponders attached to said media;

a chamber electromagnetically coupled to said radio frequency interrogator for increasing the field strength of the radio frequency interrogation field transmitted to said radio frequency transponders when said 15 media is placed therein; and

a radio frequency identification label, further comprising:

a label having a first surface suitable for receiving at least one of textual and optically readable indicia and a second surface suitable for being attached to a medium; and

20 a radio frequency transponder affixed to said label and configured to respond to the radio frequency interrogation field generated by said interrogator;

wherein said radio frequency transponder is positioned and oriented such that wherein said label is attached to a first medium in closely spaced 25 relation to a second medium having a second radio frequency identification label attached thereto, diversity of said radio frequency identification system is increased.

19. The radio frequency identification system in accordance with 30 Claim 18, wherein said label further comprises a second surface at least partially coated with an adhesive for adhering said label to the medium.

20. The radio frequency identification system in accordance with Claim 18, wherein the radio frequency transponder further comprises:

a substrate having an area less than the area of the surface of the label;

5 an antenna circuit formed as an integral part of said substrate; and
a radio frequency identification circuit attached to said substrate and bonded to said antenna circuit.

21. The radio frequency identification system in accordance with Claim 18, wherein the label further comprises:

an indicia receiving layer; and

an insulating layer adhered to said indicia receiving layer so that said radio frequency transponder is laminated therebetween.

22. The radio frequency identification system in accordance with Claim 21, wherein said indicia receiving layer further comprises:

an outer layer providing said first surface; and

15 a second insulating layer affixed to said outer layer opposite said first surface so that said radio frequency transponder is laminated between said
20 first insulating layer and said second insulating layer.

23. The radio frequency identification system in accordance with Claim 22, wherein at least one of said first and second insulating layers comprise expanded polystyrene.

25

24. The radio frequency identification system in accordance with Claim 22, wherein said outer layer comprises paper.

25. The radio frequency identification system in accordance with Claim 20 wherein said radio frequency identification circuit further comprises
30 memory for storing information and said interrogator is configured to write information to said memory.

26. A method of manufacturing a radio frequency identification label, comprising the steps of:

5 affixing a radio frequency transponder to a label having a first surface suitable for receiving at least one of textual and optically readable indicia and a second surface suitable for being attached to a medium,

10 wherein the radio frequency transponder is positioned and oriented such that wherein the label is attached to a first medium in closely spaced relation to a second medium having a second radio frequency identification label attached thereto, at least one of positional diversity, polarization diversity and directional diversity of the first and second radio frequency transponders is increased.

27. The method of manufacturing a radio frequency identification label in accordance with Claim 26, further comprising the step of at least partially coating the second surface of the label with an adhesive for adhering the label to a medium.

28. The method of manufacturing a radio frequency identification label in accordance with Claim 26, further comprising the steps of:

affixing an indicia receiving layer to an insulating layer to form the label; and

laminating the radio frequency transponder between the indicia receiving layer and the insulating layer.

25

29. The method of manufacturing a radio frequency identification label in accordance with Claim 26, further comprising the step of:

30 affixing an outer layer providing the first surface to a second insulating layer opposite said first surface so that said radio frequency transponder is laminated between said first insulating layer and said second insulating layer.

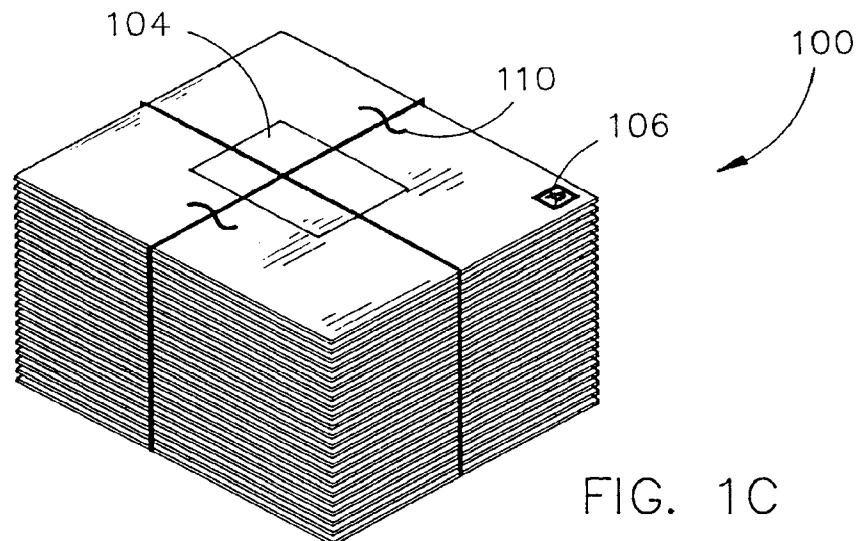
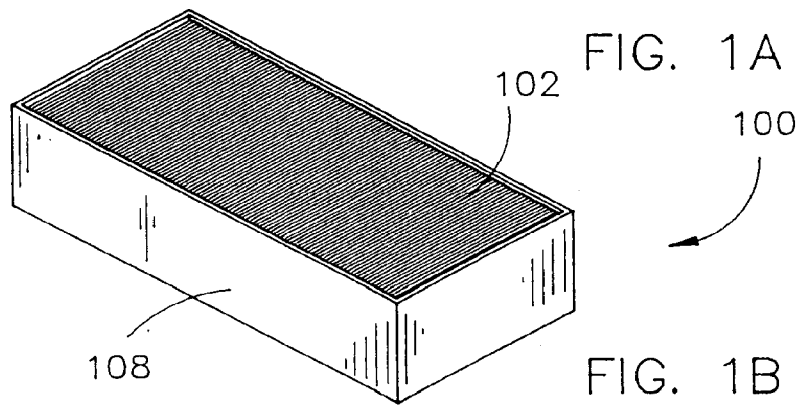
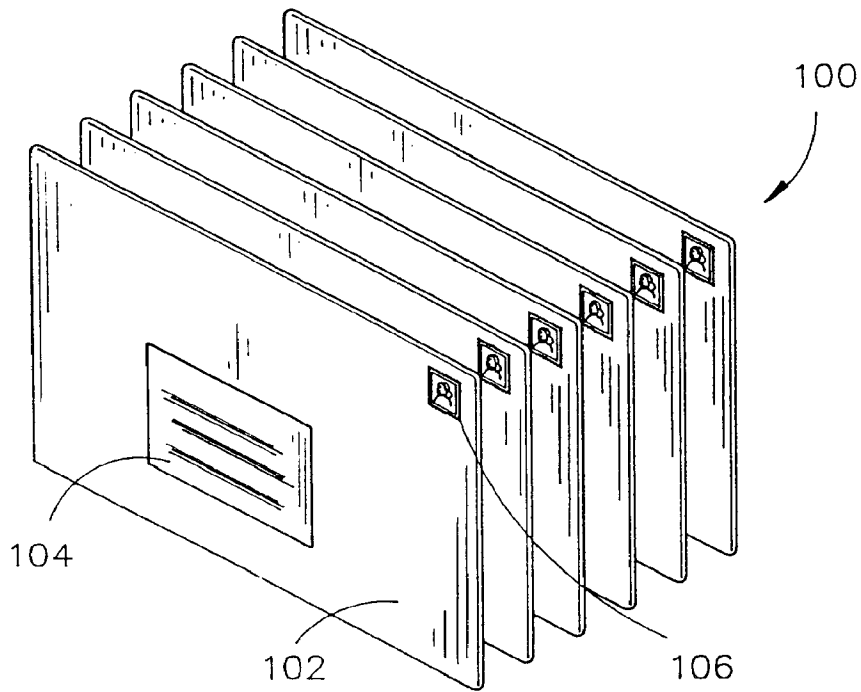

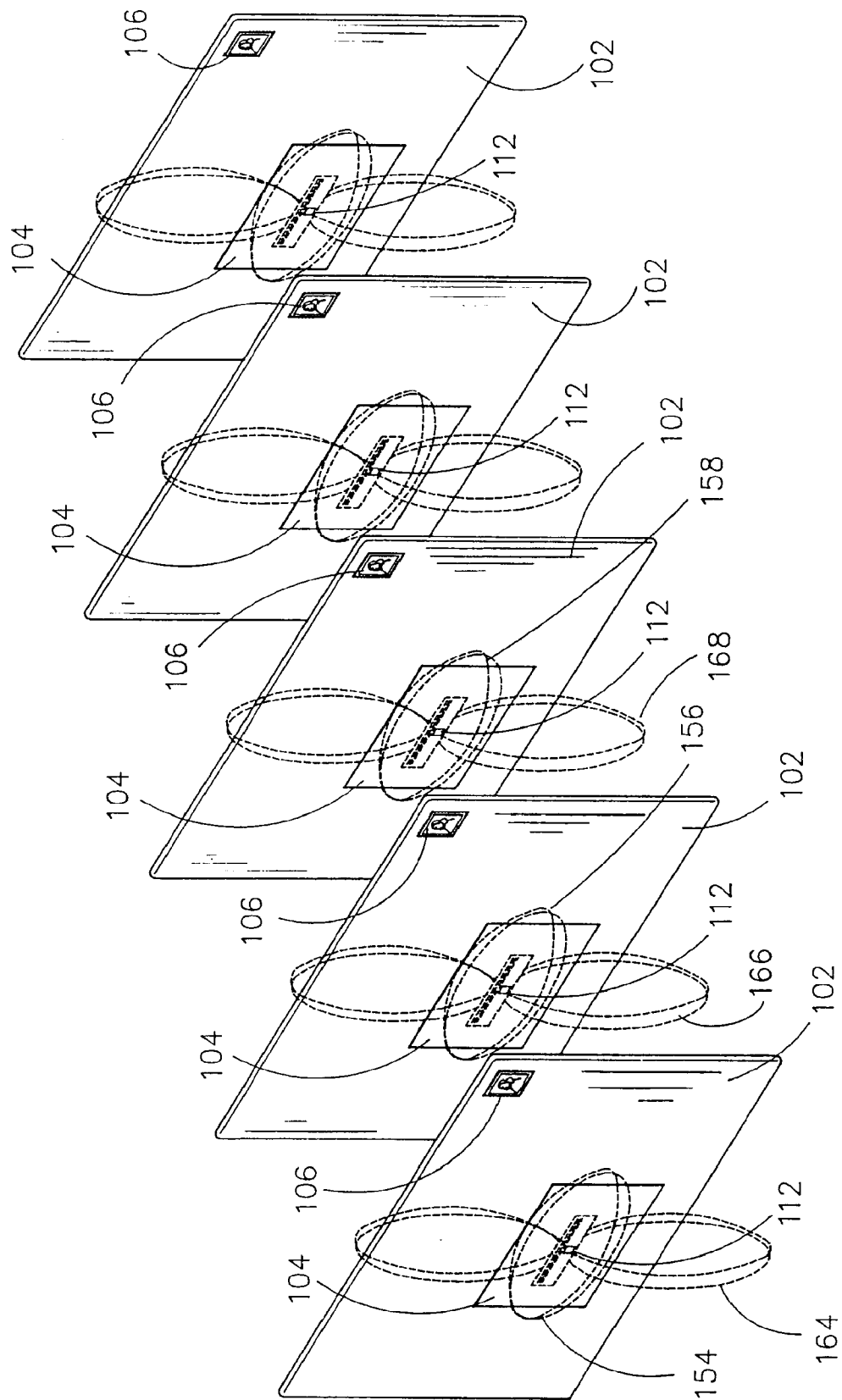

FIG. 2

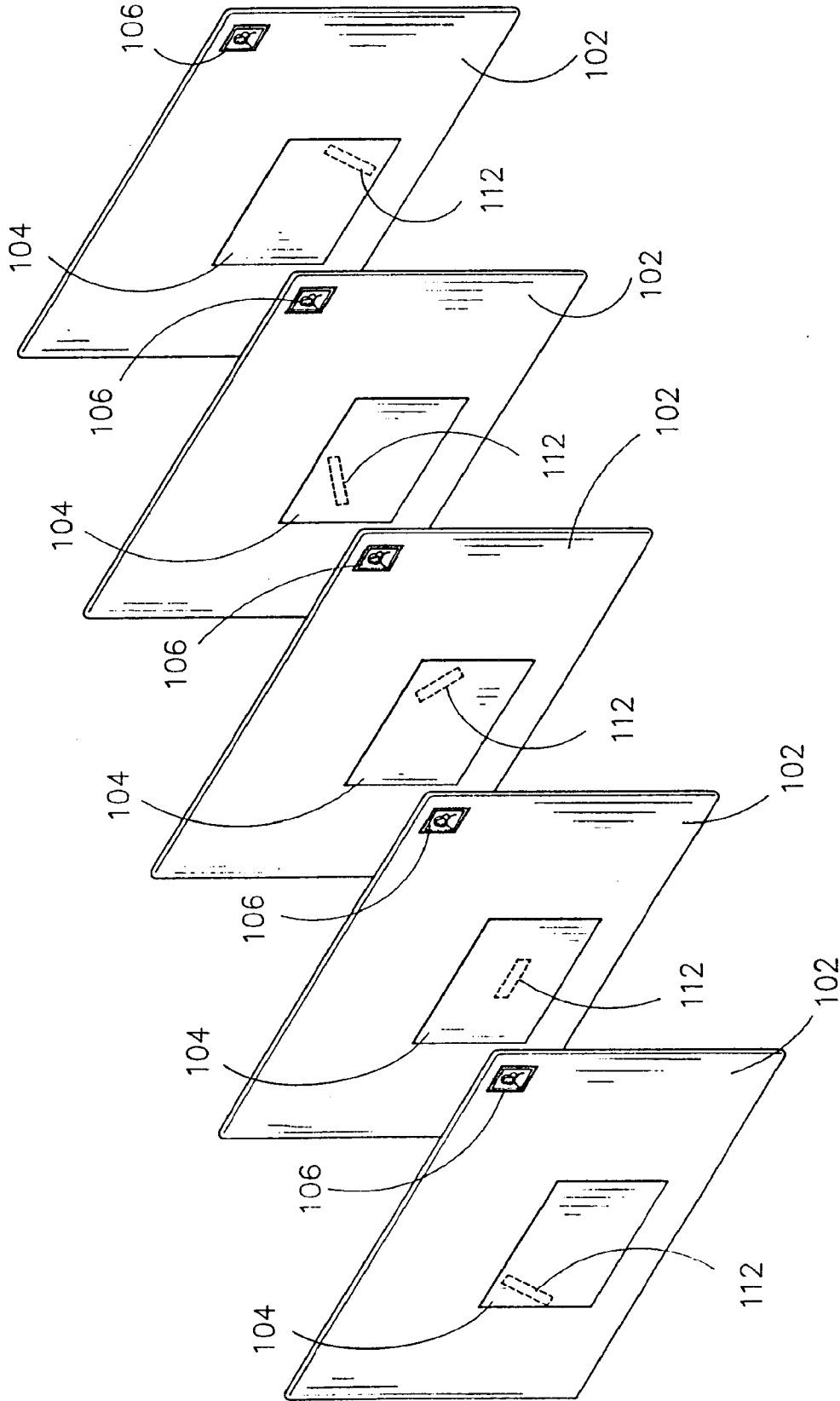

FIG. 3

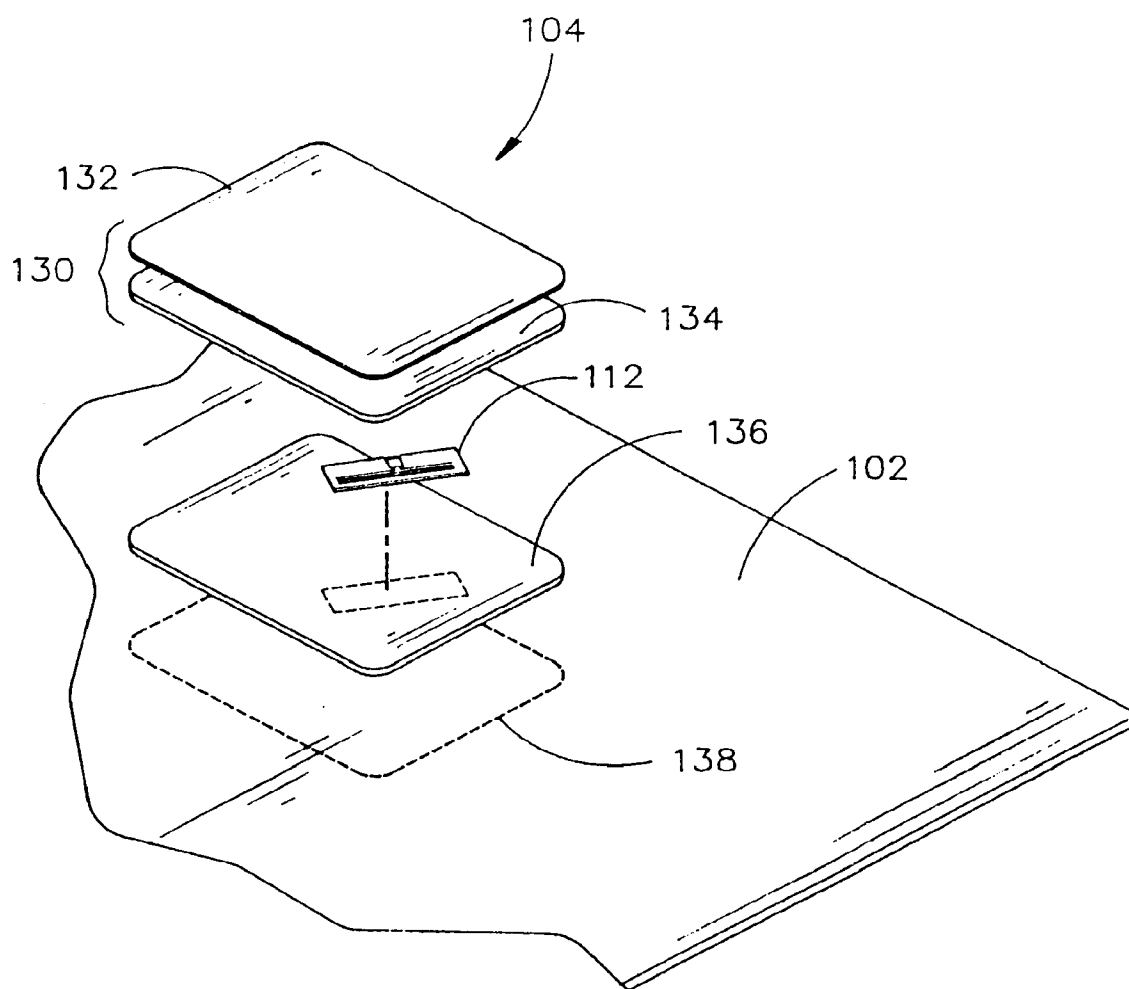

FIG. 4

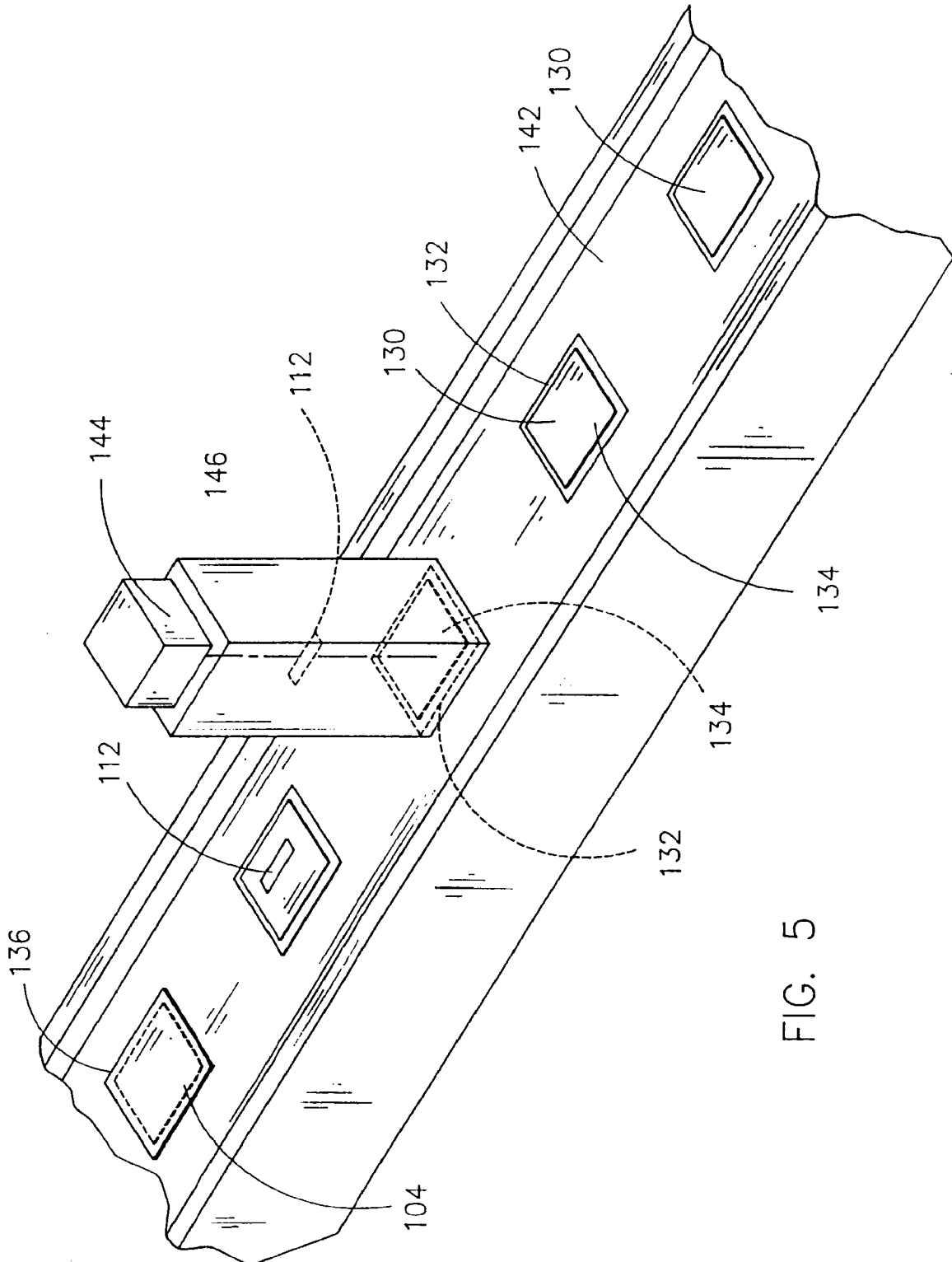

FIG. 5

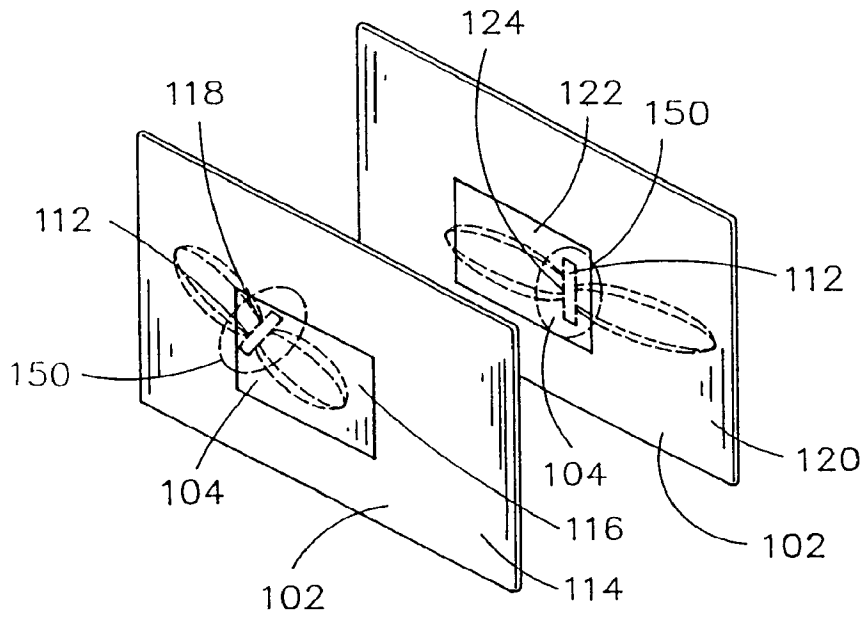

FIG. 7

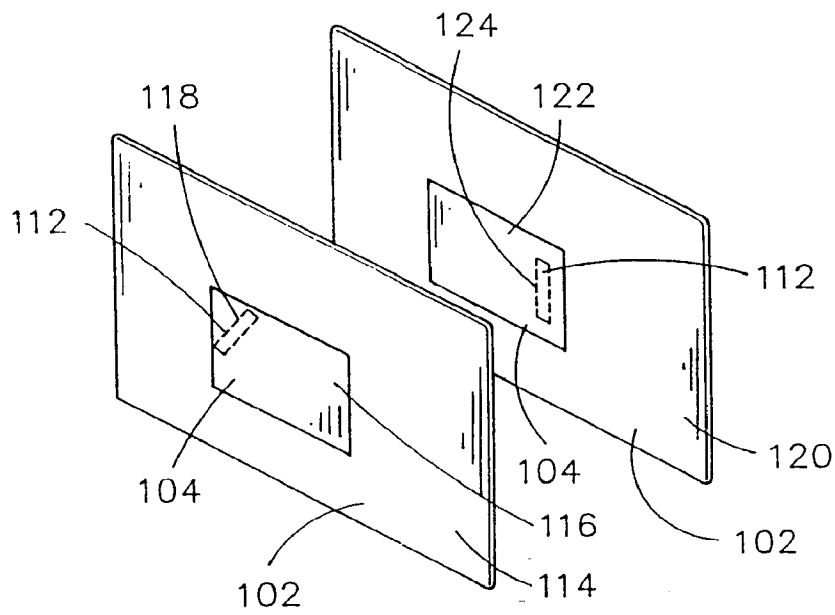

FIG. 6

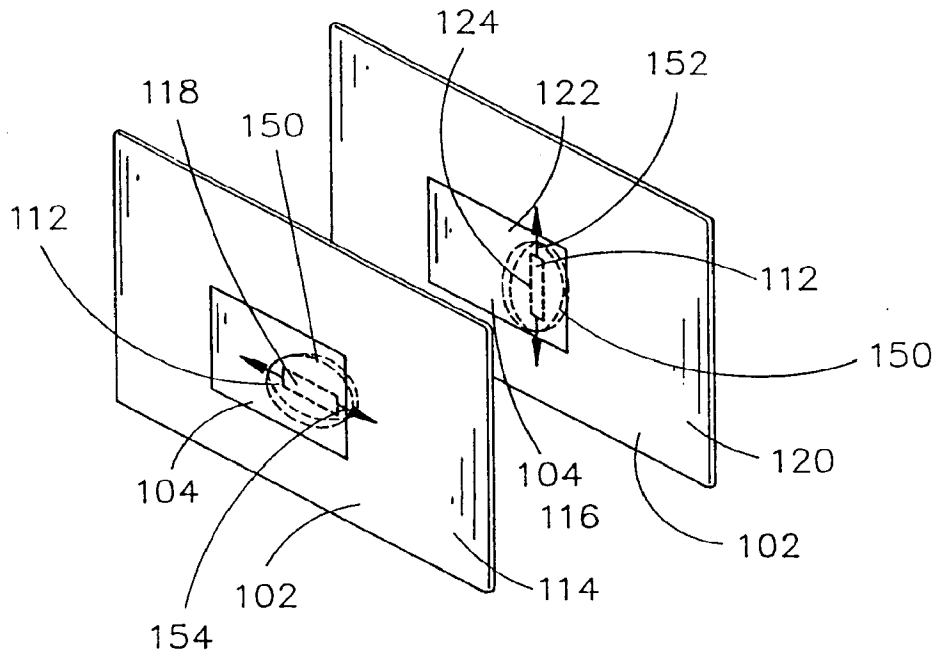

FIG. 8

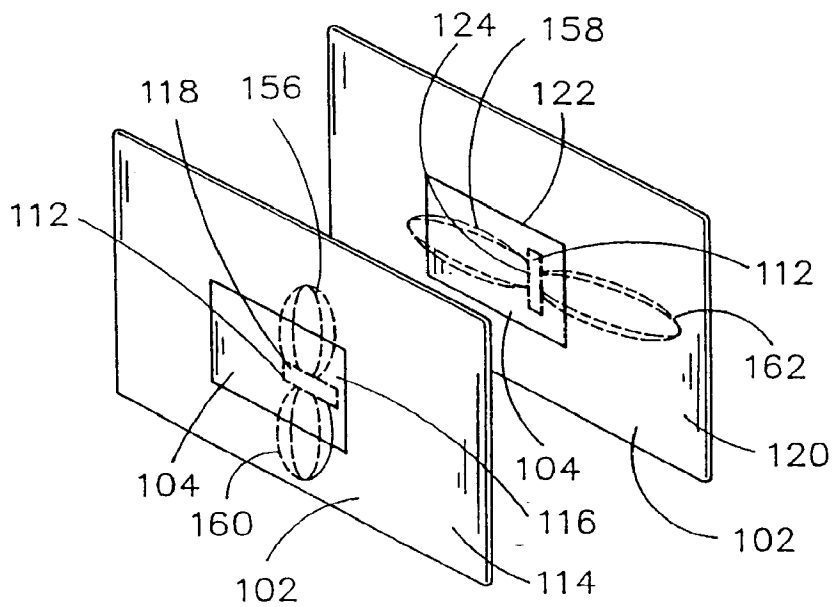

FIG. 9

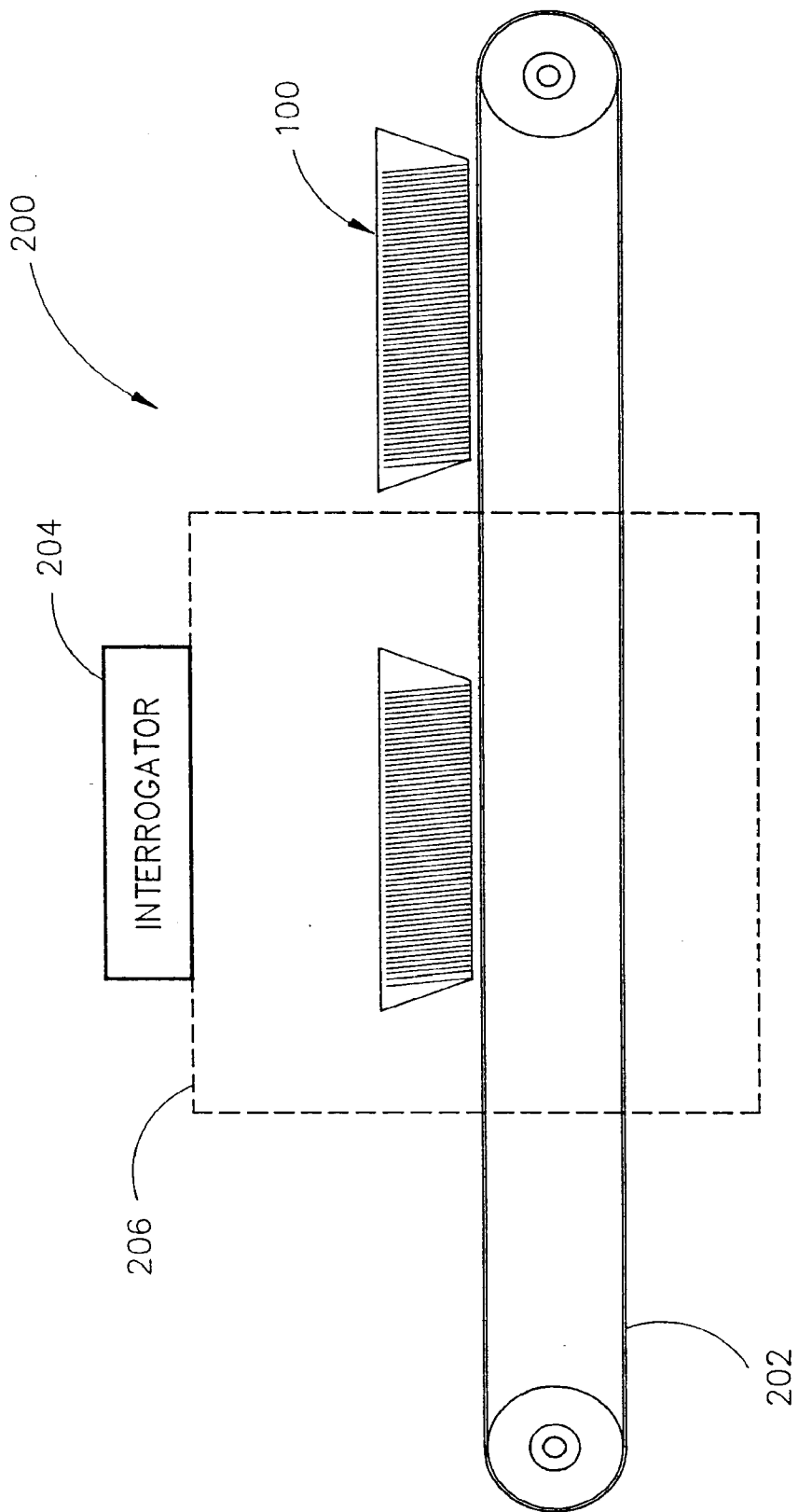

FIG. 10A

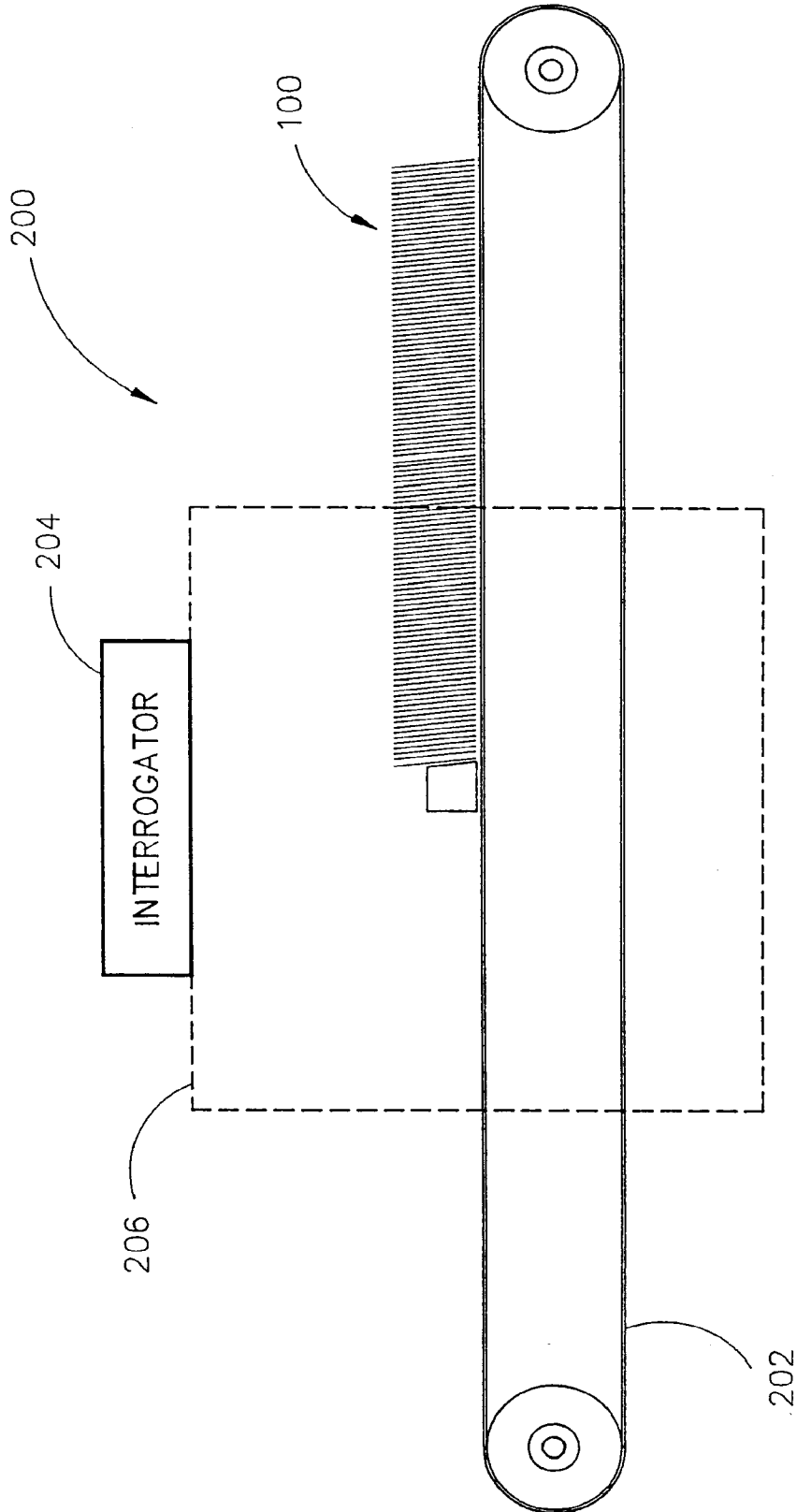

FIG. 10B

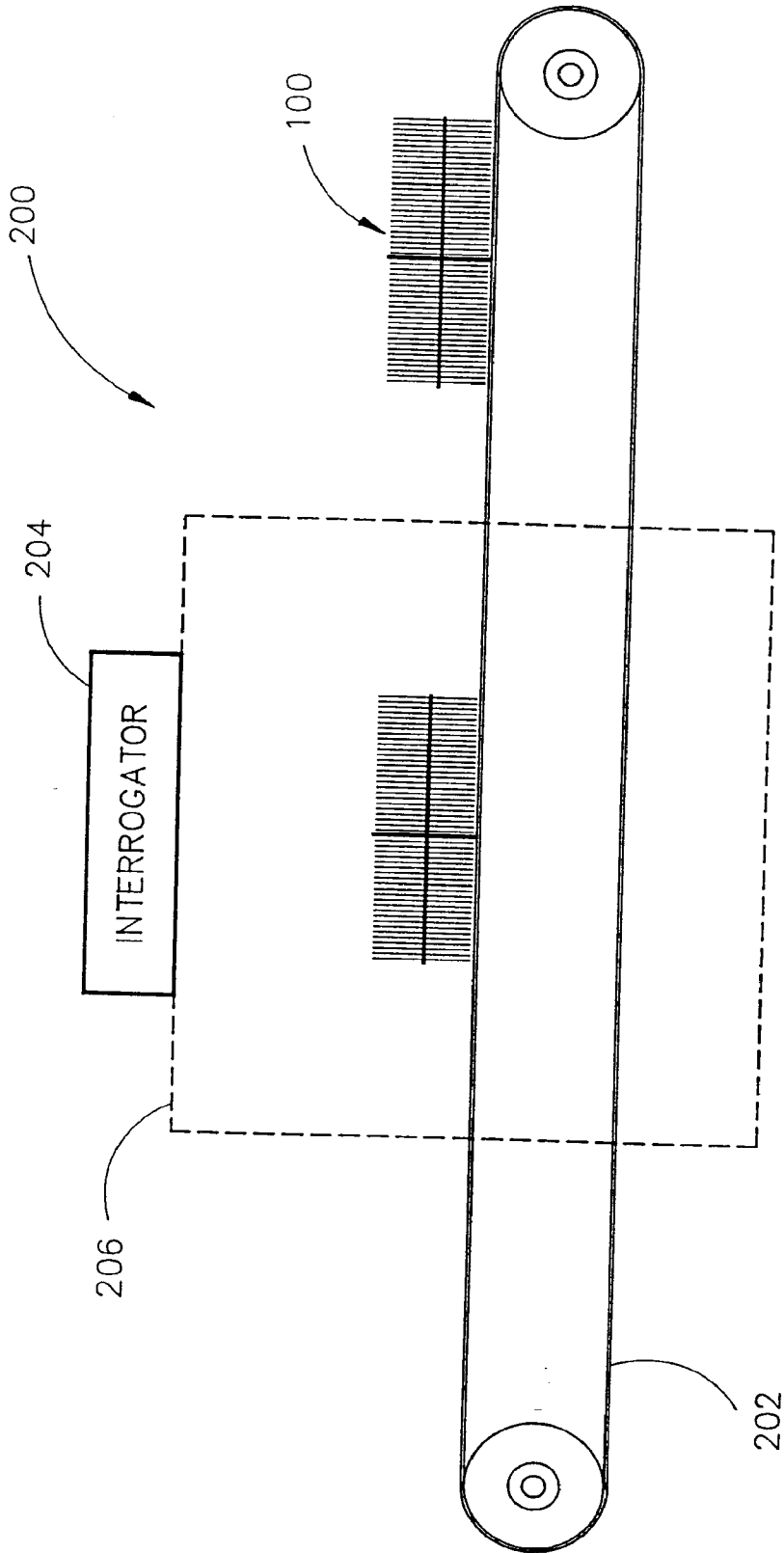

FIG. 10C

INTERNATIONAL SEARCH REPORT

International Application No
PCT/US 00/17619

A. CLASSIFICATION OF SUBJECT MATTER
IPC 7 G06K19/07 G06K19/077 G06K7/00

According to International Patent Classification (IPC) or to both national classification and IPC

B. FIELDS SEARCHED

Minimum documentation searched (classification system followed by classification symbols)
IPC 7 G06K

Documentation searched other than minimum documentation to the extent that such documents are included in the fields searched

Electronic data base consulted during the international search (name of data base and, where practical, search terms used)

WPI Data, PAJ, IBM-TDB, INSPEC, EPO-Internal

C. DOCUMENTS CONSIDERED TO BE RELEVANT

Category *	Citation of document, with indication, where appropriate, of the relevant passages	Relevant to claim No.
A	GB 2 274 373 A (MULTILOP LTD) 20 July 1994 (1994-07-20) page 4, paragraph 2 -page 6, paragraph 1; figures 1,2	1,9,10, 18,26
A	US 5 565 858 A (GUTHRIE WARREN E) 15 October 1996 (1996-10-15) abstract; figure 3A	1,9,10, 18,26
A	US 5 497 140 A (TUTTLE JOHN R) 5 March 1996 (1996-03-05) column 2, line 24 - line 67; figures 2,4	1-29

Further documents are listed in the continuation of box C.

Patent family members are listed in annex.

* Special categories of cited documents :

- *A* document defining the general state of the art which is not considered to be of particular relevance
- *E* earlier document but published on or after the international filing date
- *L* document which may throw doubts on priority claim(s) or which is cited to establish the publication date of another citation or other special reason (as specified)
- *O* document referring to an oral disclosure, use, exhibition or other means
- *P* document published prior to the international filing date but later than the priority date claimed

- *T* later document published after the international filing date or priority date and not in conflict with the application but cited to understand the principle or theory underlying the invention
- *X* document of particular relevance; the claimed invention cannot be considered novel or cannot be considered to involve an inventive step when the document is taken alone
- *Y* document of particular relevance; the claimed invention cannot be considered to involve an inventive step when the document is combined with one or more other such documents, such combination being obvious to a person skilled in the art.
- *&* document member of the same patent family

Date of the actual completion of the international search

4 October 2000

Date of mailing of the international search report

10/10/2000

Name and mailing address of the ISA
European Patent Office, P.B. 5818 Patentlaan 2
NL - 2280 HV Rijswijk
Tel. (+31-70) 340-2040, Tx. 31 651 epo nl,
Fax: (+31-70) 340-3016

Authorized officer

Chiarizia, S

INTERNATIONAL SEARCH REPORT

information on patent family members

International Application No

PCT/US 00/17619

Patent document cited in search report	Publication date	Patent family member(s)	Publication date
GB 2274373 A	20-07-1994	AU 5836894 A	15-08-1994
		WO 9416407 A	21-07-1994
US 5565858 A	15-10-1996	GB 2307370 A, B	21-05-1997
		JP 10506357 T	23-06-1998
		WO 9608760 A	21-03-1996
US 5497140 A	05-03-1996	US 5787174 A	28-07-1998
		US 6013949 A	11-01-2000
		US 5779839 A	14-07-1998